

TOP VIEW

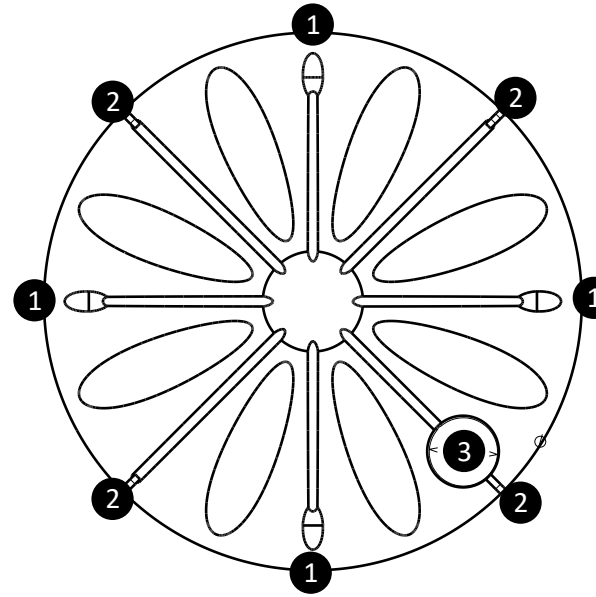

BOTTOM VIEW

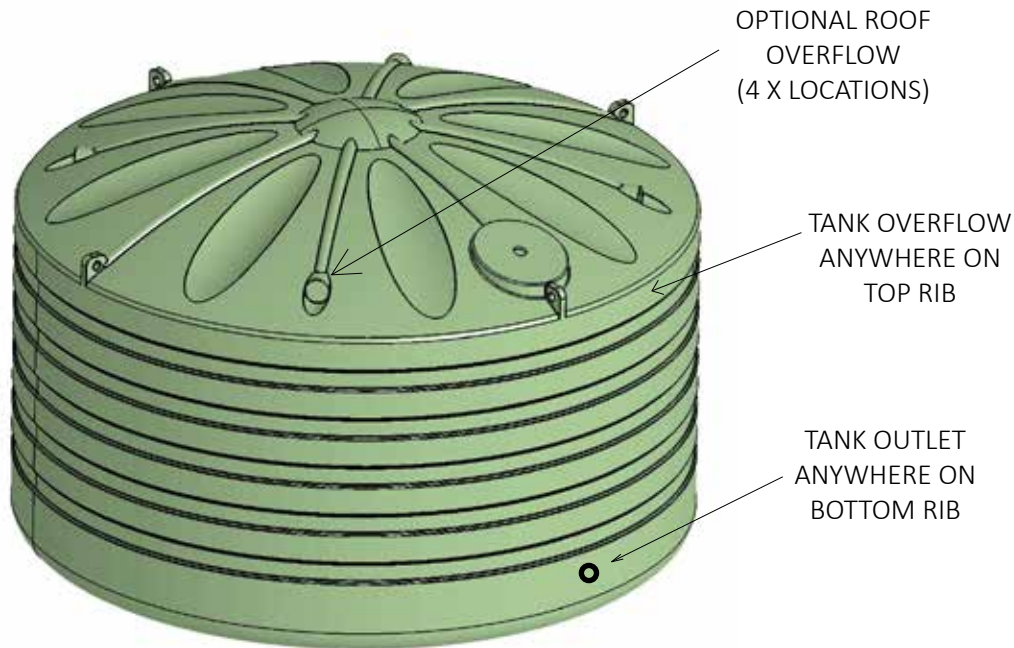
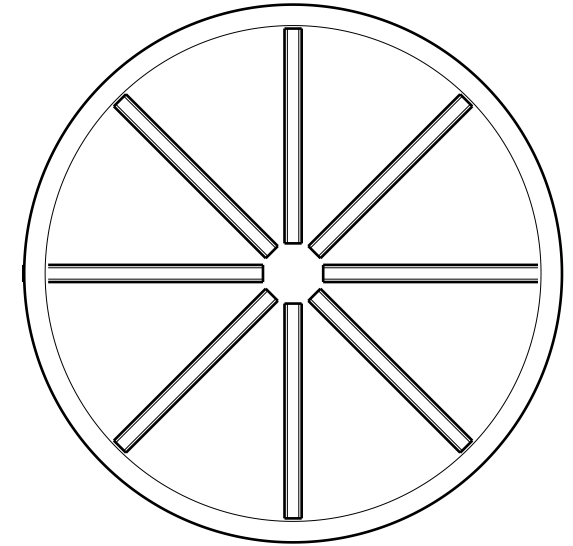

(1) OPTIONAL ROOF OVERFLOW 4 LOCATIONS (ADDITIONAL 2,000L CAPACITY)
(2) LIFTING LUGS 4 LOCATIONS
(3) TANK INLET AND STRAINER LOCATION

Important Notes

1. Driver + 2 people are required to lift the tank.
2. Recommended space required for tanks is a minimum of 200mm.
3. Standard installations have 1 x outlet and 1 x overflow.
4. Capacities and measurements may vary due to the roto-moulding process.

This drawing was prepared by APR Manufacturing Group and the copyright belongs to the company. All rights conferred by the law of copyright and by virtue of international copyright conventions are reserved to the company. Reproduction requires the prior written consent of the company. Any infringement of this copyright may result in legal action.

 29 - 33 Woomera Ave, Edinburgh SA 5111 (08) 8359 4999 sales@aprtanks.com.au www.aprtanks.com.au	20,000 LITRE ROUND TANK Product Code: T20R Material: Polyethylene
	DATE: 17.12.21 SCALE: NOT TO SCALE